

Instruction Manual for Novibra Spindles

This manual and other manuals as well, especially documents relating to safety, must be kept in such place where the staff in charge of operating and maintenance can consult them.

This manual and all information is the property of Novibra Boskovice s.r.o. The manual is intended for customers of Novibra company and it is forbidden to copy or distribute it or parts of it to a third person without prior written consent of Novibra Boskovice s.r.o.

Contents

1. Legal stipulations	3
2. General notes on safety	3
2.1. Safety precautions	3
2.2. Regional safety regulations	3
2.3. Obligatory notification	3
2.4. Maintenance work	3
2.5. Suitable clothing	3
2.6. Disposal	3
3. Spindles:	4
3.1. Basic types of bolsters	4
3.2. Top parts	4
3.3. Brakes	5
3.4. Tubes	6
4. Installation	6
4.1. Storing, transport and unpacking goods	6
4.2. Fixing of the spindle	6
4.3. Oil check before first start up	6
4.4. Installation of plastic brakes	7
5. Maintenance	7
5.1. Lubrication	7
5.2. Cutting crowns	8
5.3. Internal lock (AV lock)	8
6. Contact address	8
Appendix 1 – Recommended oil	9
Appendix 2 – Spindle care in short	10

1. Legal stipulations

The Spindles supplied by Novibra and their accessories and equipment such as cutting (clamping) crowns, brakes, tube clutch systems etc. must be used only for the purpose they are intended for and in accordance to this manual.

Novibra declines all responsibility for any damage or injury due to inappropriate or hazardous usage.

2. General notes on safety

2.1. Safety precautions

Spindles are supposed to be a part of ring spinning frame, which represents low risk, and low probability of injury of the staff.

For reasons related to operability, productivity etc. it is not possible to eliminate completely all sources of potential danger. Daily routine also demands constant attention.

It is necessary to follow the instructions in this manual and the manuals of the producers of the ring spinning frames to eliminate the risk as much as possible. All manuals, especially documents related to safety, must be kept in such place where the staff can consult them.

Appropriate steps must be taken to ensure that only authorized and trained staff has access to the machines.

Thinking about safety reduces the risk of injury and it is therefore never a waste of time.

2.2. Regional safety regulations

Local safety regulations and laws in force in the individual countries must be observed.

2.3. Obligatory notification

Should an accident occur or should it become clear that operating a spindle constitutes a potential danger (never run spindle which shows any sign of damage!), Novibra must be informed immediately in writing.

Novibra declines all liability for any damage that may occur due to failure to observe this regulation.

2.4. Maintenance work

Observe the maintenance regulations of the machine. During maintenance work, turn off the main or safety switch and secure it with a padlock. This prevents the machine being inadvertently switched on by a third person.

2.5. Suitable clothing

For operating reasons, it is not possible to secure all rotating or moving parts of a machine including spindles against accidents. The risk of accidents in such areas can be considerably reduced by wearing appropriate clothing.

- Do not wear loose clothing (long sleeves, ties etc.)
- Long hair must be specially protected. Always wear a cap.
- Do not wear rings on your fingers or wristwatches.
- Do not carry tools in open breast pockets. These objects might drop out or fall into the machine.

2.6. Disposal

Laws and regulations in force in the particular country must be obeyed for spindle at the end of its lifetime concerning reutilization, recycling, and waste disposal. Any oil, grease, plastic parts etc. must be disposed of in accordance with the regulations in force.

3. Spindles:

Novibra spindles give the best performance:

- maximum spindle speed together with high reliability and long lifetime
- good running performance with low spindle vibration and low noise level
- low energy consumption
- considerably extended lubrication intervals, less maintenance and other benefits

3.1. Basic types of bolsters:

L HPS 68	For coarser yarn counts and larger tubes. Recommended for speed up to 16 000 RPM , however, can be used up to 20 000 RPM.
HPS 68	Usual applications and recommended for speed up to 20 000 RPM . Recommended speed limit reflects the noise level requirements.
NASA HPS 68	The best performance, the lowest noise level, vibrations and longer life time in high speeds up to 30 000 RPM .
LENA	Energy saving spindle with wharve 17,5mm for speeds up to 30 000 RPM .

3.2. Top parts:

Bare blade spindles recommended for speed up to 16 000 RPM (Pic. 2)

Alu type spindles up to speed limits valid for the type of Bolster (Pic. 1), see chap.3.1.

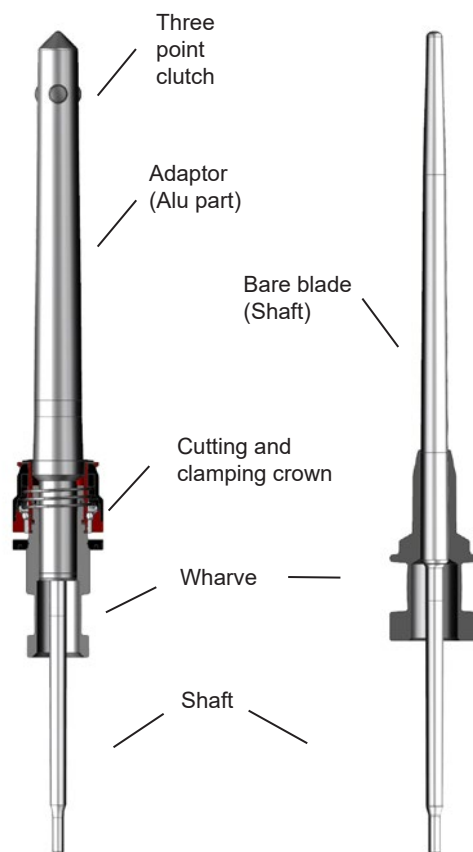

Pic. 1

Pic. 2

Attention!

- Never run spindle above recommended speed limits!
- Never run spindle, which shows any sign of damage!

Consequences:

- **Injury of the staff.**
- The spindle can be overloaded and damaged.



Recommended belt pressure 10 - 15 N

Three-point clutch

Top parts can be equipped with spring (Pic.3) or centrifugal 3-point tube clutch (Pic. 4).

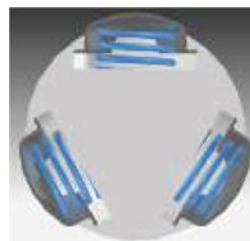

Pic. 3



Pic. 4

Safeguard of the top part

Two solutions are available - hook (Pic. 5) or internal lock (AV lock, Pic. 6)

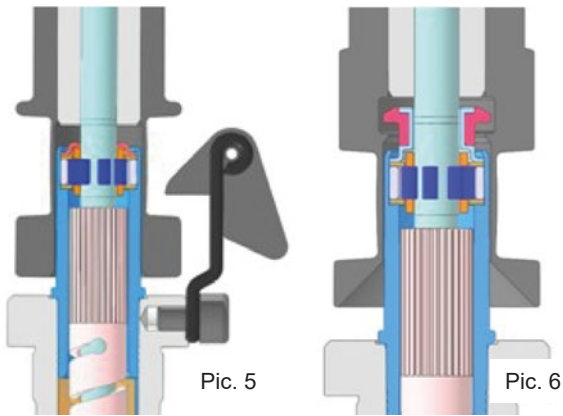

For safe removal of top part and replacing of internal lock see chapter 5.2.

Cutting crowns

There is a wide range of different cutting crowns available

For proper maintenance of crowns see chapter 5.3. and respective individual cutting crowns maintenance manuals.

3.3. Brakes:

Novibra supplies various types of brakes.

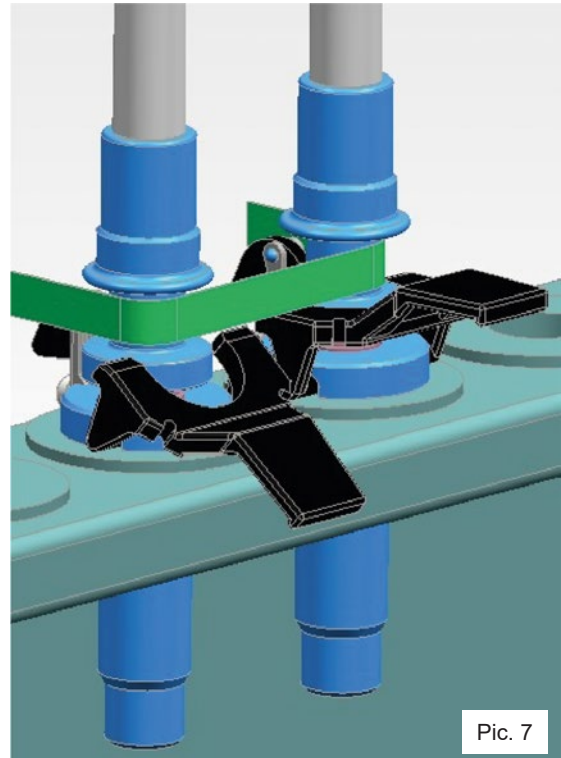

Brakes must be installed properly to prevent any damage caused by wrong installation – see chapter 4.4.

Attention!

- Never run top part, which shows any sign of damage!
- Never run top part without tube!
- Be sure that the top part is properly fixed by hook or internal lock before running!



Consequences:

- **Injury of the staff.**
- The tube clutch, tube, clamping crown, top part body or bolster can be damaged.
- The internal lock or hook can be damaged. This increases the risk of accident and may damage the autodoffer.

Attention!

Never stop rotating spindles or cops by hand ! Always use brakes !



Consequences:

- **Injury of the staff.**
- The tube clutch or the tube itself can be damaged.
- The top part or bearings of the bolster can be overloaded and damaged.

Other recommendation:

Stop one spindle per drive tape only. Always use brake. Stop the spindle for a short time only.

Consequences of stopping several spindles:

- The spindle tape heats up and may break.
- Twist loss on other spindles.

3.4. Tubes:

The tubes have to be seen as an integral part of the spindle. Bigger clearance between tube and spindle creates higher load on the neck bearing and reduces lifetime of spindle. The same is valid for bent or improper tubes. This effect is increasing with higher speed.

It must be ensured that:

- Information about tube dimensions (basic dimensions and production tolerances) must be provided to Novibra for design purposes. Clearance between tube and spindle has to be as small as possible.
- Quality of tube is sufficient for target speeds. This must be ensured and guaranteed by the tube supplier.

Novibra recommends tubes which are in accordance with ISO 368.

Attention!

Never run the spindle with an unmatching tube or damaged clutch system of top part!



Consequences:

- **Injury of the staff.**
- The tube or the spindle can be damaged.

Novibra declines all liability for any damage or injury that occurred due to running spindle with unsuitable tube.

4. Installation

4.1. Storing, transport and unpacking

Store all delivered spindle boxes in original sealed packages in a dry and clean warehouse for maximally 6 months after their delivery.

Unpack spindle boxes just before spindle installation. Make sure the installation is done in clean environment, controlled temperature and humidity. Avoid any pollution by hard particles such as sand, dust or other hard impurities.

Use textile gloves to protect spindles against sweat pollution during their installation on the machine. Fingerprints can significantly decrease applied rust protection.

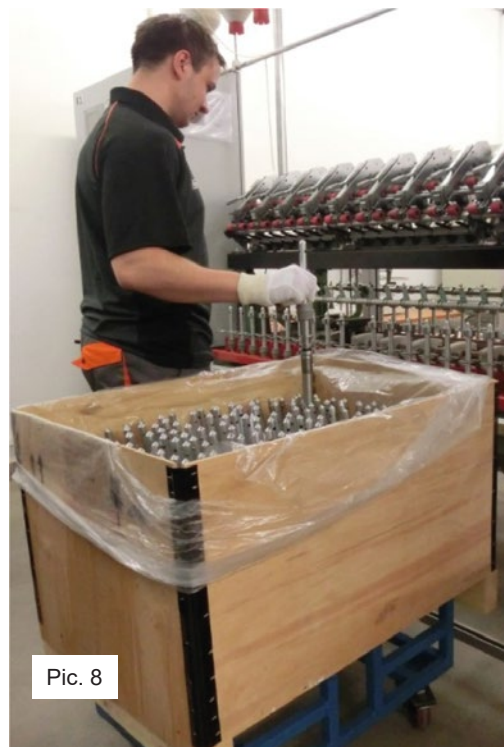

4.2. Fixing of the spindle

The tightening torque 25 Nm is recommended for standard conditions.

4.3. Oil check before first start-up

Check the oil level of minimum 2 spindles per box before the first start-up of the machine. In case the oil level is not in the required range check all spindles from the respective box and correct the oil level where necessary.

4.4. Installation of plastic brakes

Brakes must be installed properly to ensure that they won't be damaged.

Correct installation:

Fix spindle without brake on a frame. Use special nipper suitable for respective spindle type and fix the bolster by the nut (Pic. 9). Never hold the bolster by inserted plastic brake while the nut is tightened! It leads into damage of the brake!



Pic. 9

Insert only one side of the brake jaw in the bolster slot (Pic. 10)



Pic. 10

Turn the brake slowly until the other side of the brake jaw clicks to the opposite slot.

5. Maintenance

Regular maintenance is essential for long lifetime and avoids unnecessary down time. Maintenance should be scheduled.

The most important part of maintenance is correct lubrication and proper handling of spindles during installation, lubrication, centering, cops changing etc.

Attention!

- Make sure that the machine can not be switched on by a third person during maintenance!
- Do not run spindles that show any sign of damage !



Consequences:

- **Injury of the staff.**

5.1. Lubrication

Make sure that no impurities get into the spindle bearing. Remove spindle top part from bolster for the shortest time. Take care that the removed top part cannot be damaged by rough manipulation and its shaft cannot be polluted by foreign particles or impurities. Removed top part has to be handled with care.

Lubrication procedure:

- Remove the top part out of the bolster.
- Fill exact quantity of oil into the bolster. Sufficient quantity of oil is essential for oiling of neck bearing.
- To check the oil quantity, use correct oil level measuring rod only. Insert the dry measuring rod down to the bottom of the bolster. Remove the measuring rod and check whether oil level is in required range. If the oil level is not correct, add or remove the oil.
- Put spindle top part back into bolster as soon as possible. Make sure top part moves smoothly in the spindle bearing without jamming and it is secured by hook or internal lock.

Specification of the oil:

Lubricating oil viscosity ISO VG10

For more details see Appendix 1 – Recommended oils
Lubrication oil with higher viscosity ISO VG46 is recommended for spindle operating at Ne 16 and coarser or for any spindle being exposed to non-standard spinning conditions. Contact Novibra for more details.

Frequency of lubrication:

The recommended interval of spindle oil change is 12 months irrespective of the spindle running speed. Random tests of oil level and oil quality should be executed during scheduled machine maintenance.

The oil must be changed immediately, if the oil quality is decreased (e.g. remarkable change of oil colour)
Novibra spindles don't require any special running in procedure.

Equipment for lubrication:

Novibra oiling machine for the first filling and oil changes with simultaneous cleaning of the spindle bearing.

Novibra can supply suitable lubrication adaptors for all types of Novibra spindles.

Disposal of used oil:

The particular country restrictions must be obeyed and the used oil must be disposed of in accordance with valid regulations.

Attention!

- Do not run the spindle without oil inside the bolster!
- The quality and quantity of the oil must be checked regularly!



Consequences: The spindle can be damaged.

Novibra declines all responsibility for any damage or injury that occurs due to running spindle without proper lubrication i.m. with insufficient oil level or with oil which doesn't meet the above mentioned recommendations.

5.2. Cutting crowns

Clean cutting crowns regularly from the yarn remnants. Always use suitable tool (such as a soft brush). Avoid sharp, metal tool for cleaning, especially when cutting crown is made of plastic!

Attention!

Do not clean the spindle while the spindle is running!
Consequences: **Injury of the staff.**



6. Contact address

Novibra Boskovice s.r.o.

Hrádkov 2188

CZ - 68001 Boskovice

Phone: ++420 516528189

E-mail: sales@novibra.com

The data and illustrations in this brochure IM 01 EN version 042023 and on the corresponding data carrier refer to the date of printing. Novibra reserves the right to make any necessary changes at any time and without special notice. Novibra systems and Novibra innovations are protected by patents.

5.3. Internal lock (AV lock)

Exchange of retaining ring (1):

- remove spindle top part gently by the lifting tool (Pic.14)
- cut old retaining ring (1) by a knife and remove it
- fix new retaining ring (1) with set of tools: Taper pin (2) and Punch holder (3)
- put the taper pin (2) on the top of the bolster (4) as shown on Pic.1. Insert new retaining ring (1) on the taper pin (2) and push it softly down by the punch holder (3). Use hands, not hammer!
- put top part carefully back into the bolster

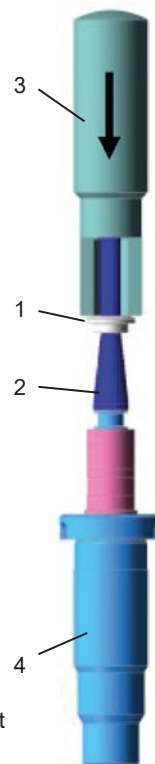

Pic. 13

Lifting tool for safe removing of top part out of the bolster. See Pic. 14



Pic. 14

Attention!

Ensure that the top part is inserted into the bolster properly and secured by the retaining ring! Consequences: **Injury of the staff.**



Appendix 1 – List of recommended oils

	VG10	VG46
Shell	Tellus S2 MA 10	Tellus S2 MA 46
Exxon Mobil	DTE 21/ DTE 11M	DTE 25
	Velocite 6	DTE 10 Excel 46
ENI Agip	AGIP OSO10	AGIP OSO46
BP Castrol	Castrol Hyspin AWS10	Castrol Hyspin AWS46
Chevron Texaco	Rando HD10	Rando HD46
Klüber	Klüberoil FT1-10BH	Klüberoil FT1-46BH

Oil quantity

Correct quantity has to be always checked by the oil level measuring rod (see below)
Put the measuring rod carefully into the bolster. The oil level must be between max. and min. marks.

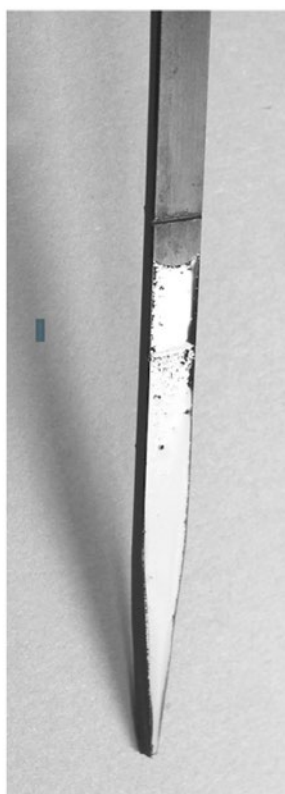
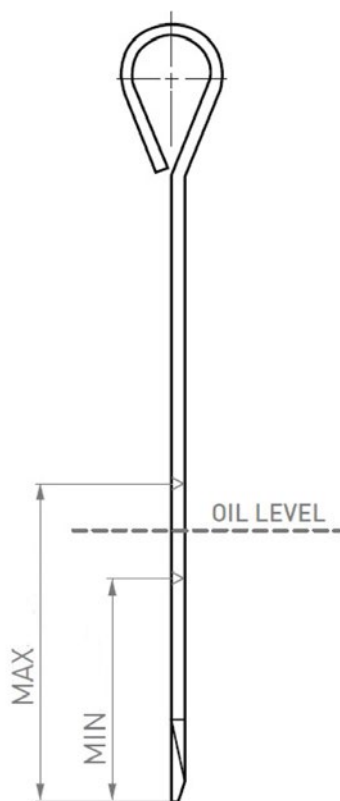

Appendix 2 – Spindle care in short

Store delivered boxes in controlled environment. Avoid excessive steps in temperature and humidity.



Use original transport boxes for deposition of spindles! Do not damage spindles by mishandling!



Use adequate forces and procedures! Do not use a hammer! Use original Novibra tools!



Tighten and lubricate the bolster properly!



Ensure that the top part is secured by hook or internal lock before running! Do not run spindle with damaged hook or internal lock!



Do not run spindles without tubes or with unmatching tubes! Do not run spindles with damaged three-point clutch or damaged tubes!



Do not touch running spindle! Do not clean rotating spindle! Do not stop spindle by hand – use brake!



Do not use any sharp tool for cleaning of spindles. Clean the spindle in the standstill only



Never run spindles, which show any sign of damage!

For more details study the Instruction manual carefully!